

# Engine Set Up Instructions

Installation of throttle return spring requires the removal of the Governor control cover. Start by removing removing (2) screws reference # 1.

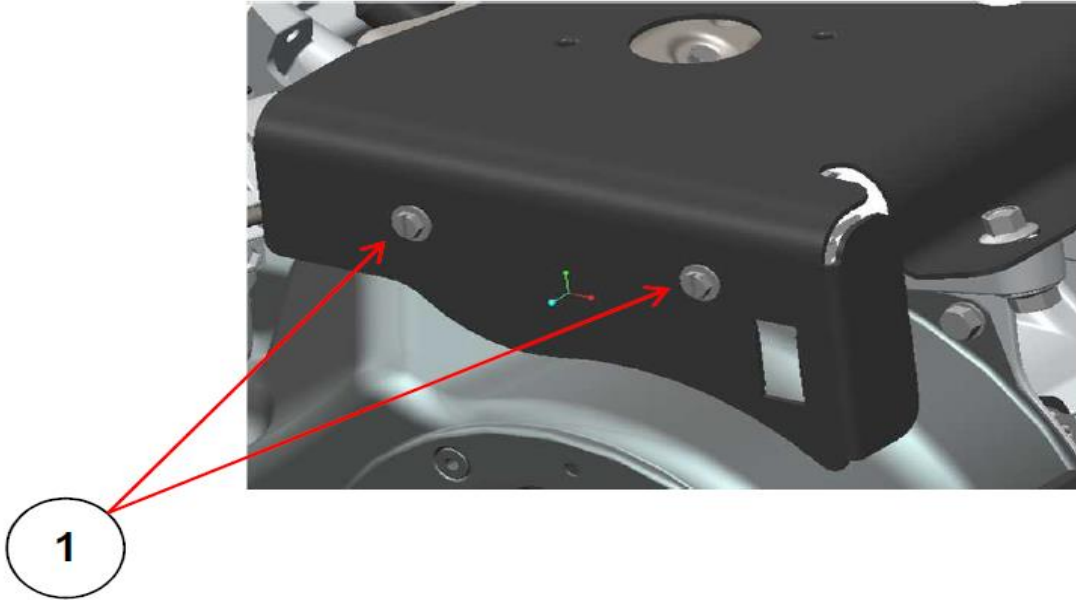

Remove bolts reference # 2 and #3.

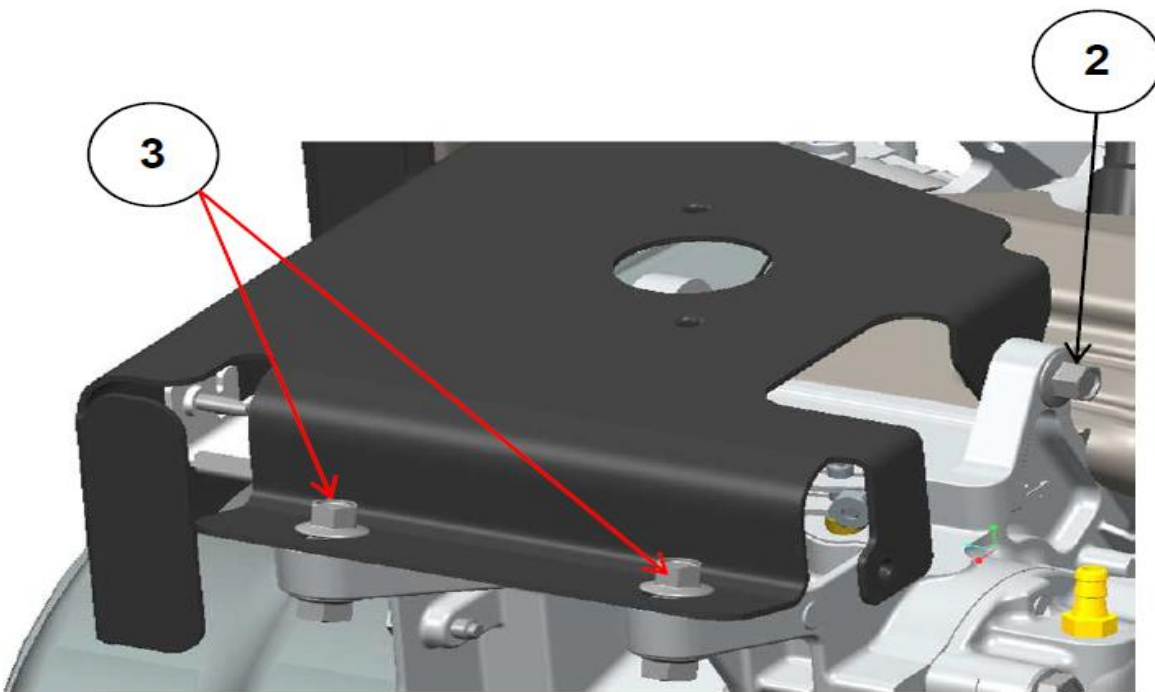

Carefully lift cover away from engine.

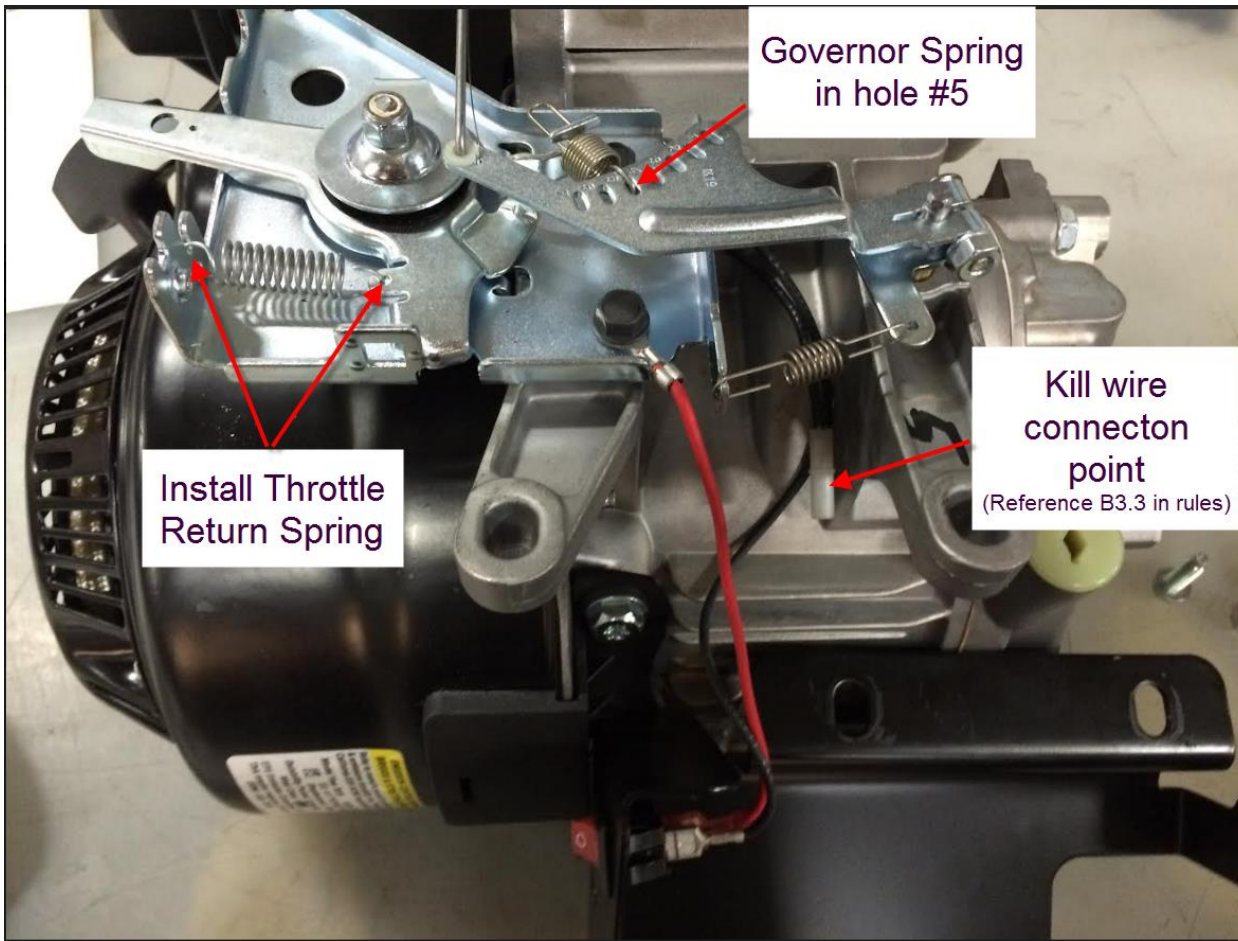

Install Throttle return spring in position shown above.

Throttle lever should now return to idle position with no resistance, if needed slightly loosen nut above throttle lever to remove any tension.

Verify governor spring is in hole #5. (Reference B2.5.14 in rules)

Note White Barrel wire Connector is for making kill switch connection. (Reference B3.3 in rules)

Reinstall governor control cover, make sure kill switch wires are connected to engine kill switch and do not pinch any wires when reinstalling cover.

After cover is reinstalled install barrel nut (note that the barrel nut will not go thru slot in cover)

## Install Barrel Nut After Idle Return Spring is Installed

- 1) Secure barrel nut to throttle lever with retaining clip
- 2) Install throttle cable bracket, torque screw to **35-55 LB-IN [4.0-6.2 N-m]**
- 3) Install throttle cable end into hole on barrel nut, snug screw to secure cable  
**Note: When remote cable is installed, ensure that wire moves freely**

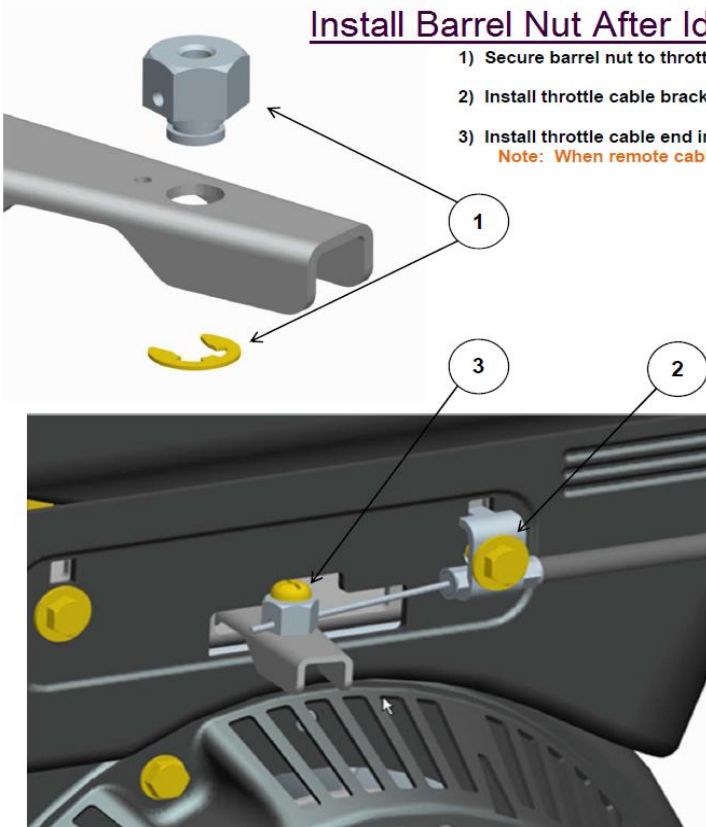

**Add engine oil, engine is equipped with two oil fill / dipsticks to allow checking and or oil filling from multiple locations.**

